

Water Test Kit (WTK) for Tap and Surface Water

Cyclopure's PFAS test kit with DEXSORB provides a convenient, affordable and accurate way to detect PFAS chemicals in water. WTK enables accurate PFAS testing of a grab sample, simply by passing water through a DEXSORB loaded extraction disc. There is no shipping water back to the lab.



Point of Site Extraction

DEXSORB's rapid kinetics and high capacity enable Point of Site extraction of 55 PFAS analytes. See Appendix A for full list. This method permits real-time capture of PFAS from tap water and surface sources, securing contaminant concentrations in actual conditions. This eliminates the risk of contaminant loss or transformation associated with the shipment of a water sample.

Quantifiable Elution

DEXSORB is compatible with analytical applications of solid-phase extraction (SPE) and passive sampling. With no requirement of complex conditioning, DEXSORB can be applied in multiple testing formats of WTK, SPE cartridges, and passive samplers to extract PFAS in diverse matrices from drinking water to wastewater. Extracted PFAS can be quantitatively recovered by standard EPA methods of elution.

Analytical Methods

Cyclopure's analytical lab employs isotope dilution methods for PFAS measurement on HPLC-MS/MS. The analysis of water samples is validated to the requirements of EPA Methods 533, 537 and 1633. All methods follow EPA instrument procedures for internal standardization and calibration certification. Cyclopure chemists provide an industry best reporting limit of 1.0 ppt. Reporting limits have been validated to the accuracy criteria of EPA methods, including Minimum Reporting Limit (MRL) confirmation.

Commercial Lab Comparisons

Our analytical method using DEXSORB for PFAS sampling has been validated in cross-laboratory, side-by-side, and split sample testing. Cyclopure's WTK has shown superior consistency and accuracy in side-by-side comparison studies with commercial labs, with Pearson Correlation values of 99.5% and paired t-test scores over 96%. Internal split sample testing of WTK and EPA Method 1633 have provided 99% accuracy of method results.

Widespread Use - Residential, State, Research

To date, Cyclopure has tested over 7,000 water samples from all 50 States. See bubble map of data for 317 samples tested in North Carolina. Our water test kits have been used to test tap water, rivers, lakes, and streams by consumers, state agencies, research institutions, and environmental groups. Test kits have also been used in Japan, The Netherlands, and Bangladesh. Water Test Kit Pro is listed by the National Institute of Environmental Health Sciences (NIHES) as a [Sensor Technology for the 21st Century](#).

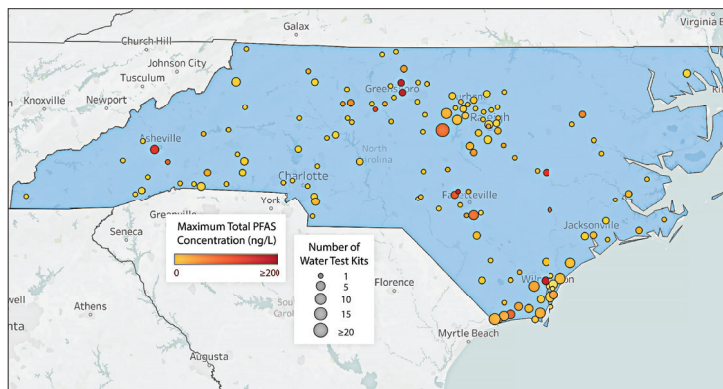

FluxTracer® for PFAS Testing in Groundwater

Cyclopure has collaborated with REGENESIS to use DEXSORB in its FluxTracer Flux Mapping Tool for PFAS monitoring in groundwater. Pre-assembled, FluxTracer is ready for well deployment as shipped. After retrieval, the FluxTracer device is repackaged and returned to Cyclopure for analysis. A vertical profile of contaminant mass flux and groundwater Darcy flux (velocity) is generated to identify contamination levels in individual vertical aquifer zones.

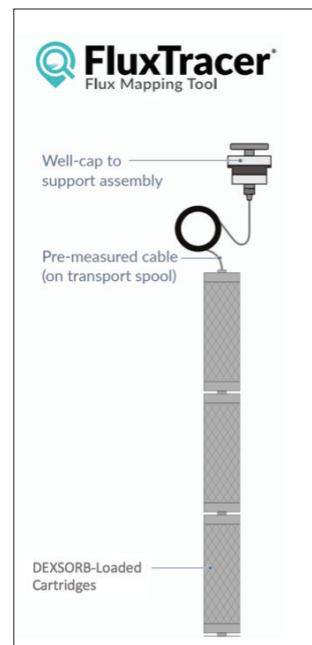

Appendix.

PFAS detected by Cyclopure analytical methods.

Compound	Abbreviation	CAS#	EPA 1633
Perfluorobutanoic Acid	PFBA	375-22-4	Y
Perfluoropentanoic Acid	PFPeA	2706-90-3	Y
Perfluorohexanoic Acid	PFHxA	307-24-4	Y
Perfluoroheptanoic Acid	PFHpA	375-85-9	Y
Perfluorooctanoic Acid	PFOA	335-67-1	Y
Perfluorononanoic Acid	PFNA	375-95-1	Y
Perfluorodecanoic Acid	PFDA	335-76-2	Y
Perfluoroundecanoic Acid	PFUnA	2058-94-8	Y
Perfluorododecanoic Acid	PFDoA	307-55-1	Y
Perfluorotridecanoic Acid	PFTrDA	72629-94-8	Y
Perfluorotetradecanoic Acid	PFTeA	376-06-7	Y
Perfluoropropane Sulfonic Acid	PFPoS	423-41-6	
Perfluorobutane Sulfonic Acid	PFBS	375-73-5	Y
Perfluoropentane Sulfonic Acid	PFPeS	2706-91-4	Y
Perfluorohexane Sulfonic Acid	PFHxS	355-46-4	Y
Perfluoroheptane Sulfonic Acid	PFHpS	375-92-8	Y
Perfluorooctane Sulfonic Acid	PFOS	1763-23-1	Y
Perfluorononane Sulfonic Acid	PFNS	474511-07-4	Y
Perfluorodecane Sulfonic Acid	PFDS	335-77-3	Y
Perfluorododecane Sulfonic Acid	PFDoS	79780-39-5	Y
4:2 Fluorotelomer Sulfonate	4:2 FTS	414911-30-1	Y
6:2 Fluorotelomer Sulfonate	6:2 FTS	425670-75-3	Y
8:2 Fluorotelomer Sulfonate	8:2 FTS	481071-78-7	Y
10:2 Fluorotelomer Sulfonate	10:2 FTS	120226-60-0	
Perfluorobutane Sulfonamide	FBSA	30334-69-1	
N-Methylperfluorobutanesulfonamide	MeFBSA	68298-12-4	
Perfluorohexane Sulfonamide	FHxSA	41997-13-1	
Perfluorooctane Sulfonamide	PFOSA	754-91-6	Y
Perfluorodecane Sulfonamide	FDSA	N/A	
N-Ethylperfluorooctane-1-Sulfonamide	NEtFOSA	4151-50-2	Y
N-Methylperfluorooctane-1-Sulfonamide	NMeFOSA	31506-32-8	Y
Perfluorooctane Sulfonamido Acetic Acid	FOSAA	2806-24-8	
N-Ethyl Perfluorooctane Sulfonamido Acetic Acid	NEtFOSAA	2991-50-6	Y
N-Methyl Perfluorooctane Sulfonamido Acetic Acid	NMeFOSAA	2355-31-9	Y
N-methyl perfluorooctanesulfonamidoethanol	NMeFOSE	24448-09-7	Y
N-ethyl perfluorooctanesulfonamidoethanol	NEtFOSE	1691-99-2	Y
Hexafluoropropylene Oxide Dimer Acid	HFPO-DA	13252-13-6	Y
4,8-Dioxa-3H-Perfluorononanoate	ADONA	919005-14-4	Y
Perfluoro-3-Methoxypropanoic Acid	PFMPA	377-73-1	Y
Perfluoro-4-Methoxybutanoic Acid	PFMBA	863090-89-5	Y
Perfluoro-3,6-Dioxaheptanoic Acid	NFDHA	151772-58-6	Y
9-Chlorohexadecafluoro-3-Oxanone-1-Sulfonic Acid	9Cl-PF3ONS	756426-58-1	Y
11-Chloroeicosafluoro-3-Oxanonane-1-Sulfonic Acid	11Cl-PF3OUdS	763051-92-9	Y
Perfluoro(2-ethoxyethane) Sulfonic acid	PFEESA	113507-82-7	Y
Perfluoro-4-ethylcyclohexane Sulfonic Acid	PFECHS	646-83-3	
8-Chloroperfluoro-1-Octanesulfonic Acid	8Cl-PFOS	777011-38-8	
3-Perfluoropropyl Propanoic Acid	3:3FTCA	356-02-5	Y
2h,2h,3h,3h-Perfluorooctanoic Acid	5:3FTCA	914637-49-3	Y
3-Perfluoroheptyl propanoic acid	7:3FTCA	812-70-4	Y
2H-Perfluoro-2-dodecenoic acid	FDUEA	70887-94-4	
2H-perfluoro-2-decenoic acid	FOUEA	70887-84-2	
Bis(perfluorohexyl)phosphinic acid	6:6PFPI	40143-77-9	
(Heptadecafluorooctyl)(tridecafluorohexyl) Phosphinic Acid	6:8PFPI	610800-34-5	
Bis(perfluorooctyl)phosphinic acid	8:8PFPI	40143-79-1	
N-(3-dimethylaminopropan-1-yl) perfluoro-1-hexanesulfonamide	N-AP-FHxSA	50598-28-2	